



# TSCHORN®

Probes & Tools Technology



Saw blade holders



## Saw blade holders

### Application:

For precise holding of saw blades.

### Type:

With parallel shank for a fixture in plain chuck jaws, high true running accuracy.



For the precise use of your saw blade holder, please pay attention to the correct insertion of the washer (see picture below). When choosing your cutting data, e.g. cutting speed and the feed rate, please take into account that your saw blade is only held by surface pressure. Too high cutting data or a dull saw blade can lead to hooking or stopping of the saw blade which can result in damages at your workpiece, saw blade, saw blade holder or even at your machine.

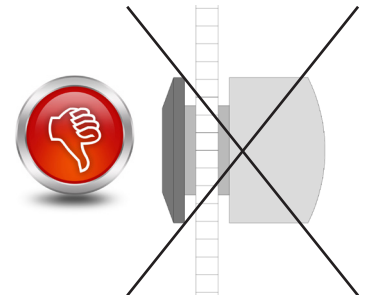
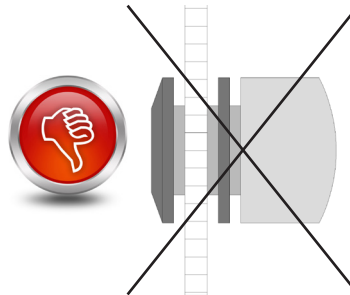
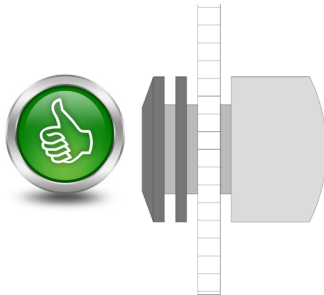

Article No.	Description	L1	L2	D1	D2	D3	K	S
0000S1020	Holder for saw blade Ø20	75	30	Ø10	Ø10	Ø5	2,5	1
0000S2020	Holder for saw blade Ø20	90	30	Ø20	Ø10	Ø5	2,5	1
0000S1025	Holder for saw blade Ø25	88	48	Ø10	Ø13	Ø8	2,5	1
0000S2025	Holder for saw blade Ø25	100	42	Ø20	Ø13	Ø8	2,5	1
0000S1032	Holder for saw blade Ø32	93	53	Ø10	Ø16	Ø8	2,5	1
0000S2032	Holder for saw blade Ø32	105	53	Ø20	Ø16	Ø8	2,5	1
0000S1040	Holder for saw blade Ø40	100	60	Ø10	Ø19,5	Ø10	3	1
0000S2040	Holder for saw blade Ø40	110	60	Ø20	Ø19,5	Ø10	3	1
0000S1650	Holder for saw blade Ø50	126	78	Ø16	Ø24,5	Ø13	3	1
0000S2550	Holder for saw blade Ø50	136	78	Ø25	Ø24,5	Ø13	3	1
0000S1663	Holder for saw blade Ø63	126	78	Ø16	Ø24,5	Ø16	3	1
0000S2563	Holder for saw blade Ø63	136	78	Ø25	Ø24,5	Ø16	3	1
0000S2080	Holder for saw blade Ø80	142	92	Ø20	Ø34	Ø22	4	1
0000S2580	Holder for saw blade Ø80	150	92	Ø25	Ø34	Ø22	4	1
0000S2010	Holder for saw blade Ø100	142	92	Ø20	Ø39,5	Ø22	4	1
0000S2510	Holder for saw blade Ø100	150	92	Ø25	Ø39,5	Ø22	4	1

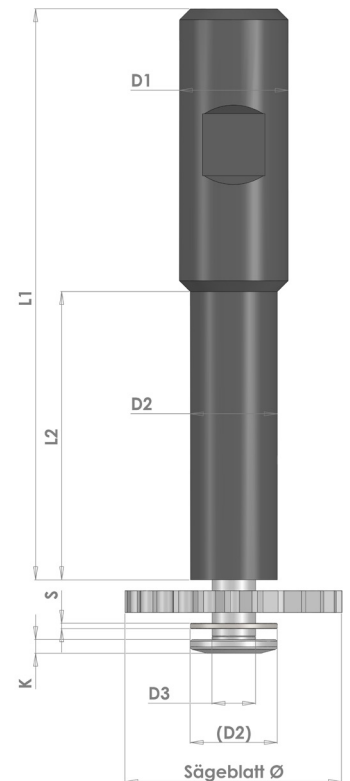

You can find suitable saw blades on page 88.

## Saw blade holder set

Saw blade holders in the following sizes: Ø20, Ø25, Ø32, Ø40, Ø50 and Ø63 with allen key in a suitcase.



Saw blade holders

Article No.	Description
0000S0020	Saw blade holder set

## Spare parts

### Safe use of the saw blade holders:

The saw blade stops rotation when the cutting force is greater than the holding force. This can happen because chips have got stuck, the saw blade is worn or blunt or the cutting values have been selected inappropriately.

As the spindle continues rotation, a stopped saw blade can inevitably result in the screw being screwed into the saw blade holder and consequently shearing off the screw head completely.

If your saw blade or the screw is broken, please check whether the saw blade holder, the screw or the washer are damaged. If in doubt, we also recommend replacing the washer, as it protects and ensures the precision of your saw blade holder.

Article No.	Description	Size
0101S2020	Spare spring washer for saw blade holder	Ø20
0101S2025	Spare spring washer for saw blade holder	Ø25
0101S2032	Spare spring washer for saw blade holder	Ø32
0101S2040	Spare spring washer for saw blade holder	Ø40
0101S2550	Spare spring washer for saw blade holder	Ø50
0101S2563	Spare spring washer for saw blade holder	Ø63
0101S4080	Spare spring washer for saw blade holder	Ø80
0101S4010	Spare spring washer for saw blade holder	Ø100
0102S2020	Spare screw for saw blade holder	Ø20
0102S2025	Spare screw for saw blade holder	Ø25
0102S2032	Spare screw for saw blade holder	Ø32
0102S2040	Spare screw for saw blade holder	Ø40
0102S2550	Spare screw for saw blade holder	Ø50
0102S2563	Spare screw for saw blade holder	Ø63
0102S4080	Spare screw for saw blade holder	Ø80
0102S4010	Spare screw for saw blade holder	Ø100

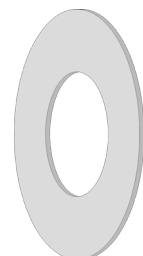

Art. No.	Saw blades fine
PASBF020020	Saw blade fine VHM-A 20x0,20x5-Z=80
PASBF020025	Saw blade fine VHM-A 20x0,25x5-Z=64
PASBF020030	Saw blade fine VHM-A 20x0,30x5-Z=64
PASBF020035	Saw blade fine VHM-A 20x0,35x5-Z=64
PASBF020040	Saw blade fine VHM-A 20x0,40x5-Z=64
PASBF020050	Saw blade fine VHM-A 20x0,50x5-Z=48
PASBF020060	Saw blade fine VHM-A 20x0,60x5-Z=48
PASBF020070	Saw blade fine VHM-A 20x0,70x5-Z=48
PASBF020080	Saw blade fine VHM-A 20x0,80x5-Z=48
PASBF020090	Saw blade fine VHM-A 20x0,90x5-Z=40
PASBF020100	Saw blade fine VHM-A 20x1,00x5-Z=40
PASBF020110	Saw blade fine VHM-A 20x1,10x5-Z=40
PASBF020120	Saw blade fine VHM-A 20x1,20x5-Z=40
PASBF020130	Saw blade fine VHM-A 20x1,30x5-Z=40
PASBF020140	Saw blade fine VHM-A 20x1,40x5-Z=40
PASBF020150	Saw blade fine VHM-A 20x1,50x5-Z=40
PASBF020160	Saw blade fine VHM-A 20x1,60x5-Z=40
PASBF020170	Saw blade fine VHM-A 20x1,70x5-Z=40
PASBF020180	Saw blade fine VHM-A 20x1,80x5-Z=32
PASBF020190	Saw blade fine VHM-A 20x1,90x5-Z=32
PASBF020200	Saw blade fine VHM-A 20x2,00x5-Z=32
PASBF020250	Saw blade fine VHM-A 20x2,50x5-Z=32
PASBF020300	Saw blade fine VHM-A 20x3,00x5-Z=32
PASBF020350	Saw blade fine VHM-A 20x3,50x5-Z=24
PASBF020400	Saw blade fine VHM-A 20x4,00x5-Z=24
PASBF020500	Saw blade fine VHM-A 20x5,00x5-Z=24
PASBF020600	Saw blade fine VHM-A 20x6,00x5-Z=24
PASBF025020	Saw blade fine VHM-A 25x0,20x8-Z=80
PASBF025025	Saw blade fine VHM-A 25x0,25x8-Z=80
PASBF025030	Saw blade fine VHM-A 25x0,30x8-Z=80
PASBF025035	Saw blade fine VHM-A 25x0,35x8-Z=64
PASBF025040	Saw blade fine VHM-A 25x0,40x8-Z=64
PASBF025050	Saw blade fine VHM-A 25x0,50x8-Z=64
PASBF025060	Saw blade fine VHM-A 25x0,60x8-Z=64
PASBF025070	Saw blade fine VHM-A 25x0,70x8-Z=48
PASBF025080	Saw blade fine VHM-A 25x0,80x8-Z=48
PASBF025090	Saw blade fine VHM-A 25x0,90x8-Z=48
PASBF025100	Saw blade fine VHM-A 25x1,00x8-Z=48
PASBF025110	Saw blade fine VHM-A 25x1,10x8-Z=48
PASBF025120	Saw blade fine VHM-A 25x1,20x8-Z=48
PASBF025130	Saw blade fine VHM-A 25x1,30x8-Z=40
PASBF025140	Saw blade fine VHM-A 25x1,40x8-Z=40
PASBF025150	Saw blade fine VHM-A 25x1,50x8-Z=40
PASBF025160	Saw blade fine VHM-A 25x1,60x8-Z=40
PASBF025170	Saw blade fine VHM-A 25x1,70x8-Z=40
PASBF025180	Saw blade fine VHM-A 25x1,80x8-Z=40
PASBF025190	Saw blade fine VHM-A 25x1,90x8-Z=40
PASBF025200	Saw blade fine VHM-A 25x2,00x8-Z=40
PASBF025250	Saw blade fine VHM-A 25x2,50x8-Z=40
PASBF025300	Saw blade fine VHM-A 25x3,00x8-Z=32
PASBF025350	Saw blade fine VHM-A 25x3,50x8-Z=32
PASBF025400	Saw blade fine VHM-A 25x4,00x8-Z=32
PASBF025500	Saw blade fine VHM-A 25x5,00x8-Z=32
PASBF025600	Saw blade fine VHM-A 25x6,00x8-Z=24
PASBF030020	Saw blade fine VHM-A 30x0,20x8-Z100
PASBF030025	Saw blade fine VHM-A 30x0,25x8-Z100
PASBF030030	Saw blade fine VHM-A 30x0,30x8-Z=80
PASBF030035	Saw blade fine VHM-A 30x0,35x8-Z=80
PASBF030040	Saw blade fine VHM-A 30x0,40x8-Z=80
PASBF030050	Saw blade fine VHM-A 30x0,50x8-Z=80
PASBF030060	Saw blade fine VHM-A 30x0,60x8-Z=64
PASBF030070	Saw blade fine VHM-A 30x0,70x8-Z=64
PASBF030080	Saw blade fine VHM-A 30x0,80x8-Z=64
PASBF030090	Saw blade fine VHM-A 30x0,90x8-Z=64
PASBF030100	Saw blade fine VHM-A 30x1,00x8-Z=64
PASBF030110	Saw blade fine VHM-A 30x1,10x8-Z=64
PASBF030120	Saw blade fine VHM-A 30x1,20x8-Z=48
PASBF030130	Saw blade fine VHM-A 30x1,30x8-Z=48
PASBF030140	Saw blade fine VHM-A 30x1,40x8-Z=48

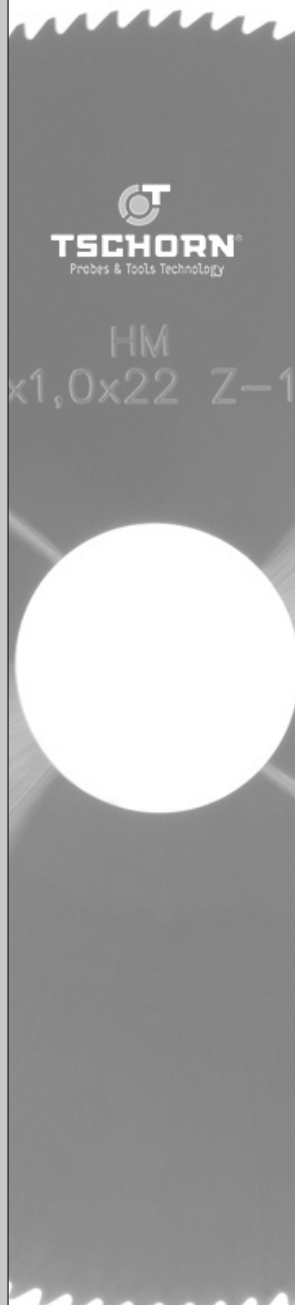

Art. No.	Saw blades fine
PASBF030150	Saw blade fine VHM-A 30x1,50x8-Z=48
PASBF030160	Saw blade fine VHM-A 30x1,60x8-Z=48
PASBF030170	Saw blade fine VHM-A 30x1,70x8-Z=48
PASBF030180	Saw blade fine VHM-A 30x1,80x8-Z=48
PASBF030190	Saw blade fine VHM-A 30x1,90x8-Z=48
PASBF030200	Saw blade fine VHM-A 30x2,00x8-Z=48
PASBF030250	Saw blade fine VHM-A 30x2,50x8-Z=40
PASBF030300	Saw blade fine VHM-A 30x3,00x8-Z=40
PASBF030350	Saw blade fine VHM-A 30x3,50x8-Z=40
PASBF030400	Saw blade fine VHM-A 30x4,00x8-Z=40
PASBF030500	Saw blade fine VHM-A 30x5,00x8-Z=32
PASBF030600	Saw blade fine VHM-A 30x6,00x8-Z=32
PASBF040020	Saw blade fine VHM-A 40x0,20x10Z128
PASBF040025	Saw blade fine VHM-A 40x0,25x10Z100
PASBF040030	Saw blade fine VHM-A 40x0,30x10Z100
PASBF040035	Saw blade fine VHM-A 40x0,35x10Z100
PASBF040040	Saw blade fine VHM-A 40x0,40x10Z100
PASBF040050	Saw blade fine VHM-A 40x0,50x10Z=80
PASBF040060	Saw blade fine VHM-A 40x0,60x10Z=80
PASBF040070	Saw blade fine VHM-A 40x0,70x10Z=80
PASBF040080	Saw blade fine VHM-A 40x0,80x10Z=80
PASBF040090	Saw blade fine VHM-A 40x0,90x10Z=64
PASBF040100	Saw blade fine VHM-A 40x1,00x10Z=64
PASBF040110	Saw blade fine VHM-A 40x1,10x10Z=64
PASBF040120	Saw blade fine VHM-A 40x1,20x10Z=64
PASBF040130	Saw blade fine VHM-A 40x1,30x10Z=64
PASBF040140	Saw blade fine VHM-A 40x1,40x10Z=64
PASBF040150	Saw blade fine VHM-A 40x1,50x10Z=64
PASBF040160	Saw blade fine VHM-A 40x1,60x10Z=64
PASBF040170	Saw blade fine VHM-A 40x1,70x10Z=48
PASBF040180	Saw blade fine VHM-A 40x1,80x10Z=48
PASBF040190	Saw blade fine VHM-A 40x1,90x10Z=48
PASBF040200	Saw blade fine VHM-A 40x2,00x10Z=48
PASBF040250	Saw blade fine VHM-A 40x2,50x10Z=48
PASBF040300	Saw blade fine VHM-A 40x3,00x10Z=48
PASBF040350	Saw blade fine VHM-A 40x3,50x10Z=48
PASBF040400	Saw blade fine VHM-A 40x4,00x10Z=40
PASBF040500	Saw blade fine VHM-A 40x5,00x10Z=40
PASBF040600	Saw blade fine VHM-A 40x6,00x10Z=40
PASBF050020	Saw blade fine VHM-A 50x0,20x13Z128
PASBF050025	Saw blade fine VHM-A 50x0,25x13Z128
PASBF050030	Saw blade fine VHM-A 50x0,30x13Z128
PASBF050035	Saw blade fine VHM-A 50x0,35x13Z100
PASBF050040	Saw blade fine VHM-A 50x0,40x13Z100
PASBF050050	Saw blade fine VHM-A 50x0,50x13Z100
PASBF050060	Saw blade fine VHM-A 50x0,60x13Z100
PASBF050070	Saw blade fine VHM-A 50x0,70x13Z=80
PASBF050080	Saw blade fine VHM-A 50x0,80x13Z=80
PASBF050090	Saw blade fine VHM-A 50x0,90x13Z=80
PASBF050100	Saw blade fine VHM-A 50x1,00x13Z=80
PASBF050110	Saw blade fine VHM-A 50x1,10x13Z=80
PASBF050120	Saw blade fine VHM-A 50x1,20x13Z=80
PASBF050130	Saw blade fine VHM-A 50x1,30x13Z=64
PASBF050140	Saw blade fine VHM-A 50x1,40x13Z=64
PASBF050150	Saw blade fine VHM-A 50x1,50x13Z=64
PASBF050160	Saw blade fine VHM-A 50x1,60x13Z=64
PASBF050170	Saw blade fine VHM-A 50x1,70x13Z=64
PASBF050180	Saw blade fine VHM-A 50x1,80x13Z=64
PASBF050190	Saw blade fine VHM-A 50x1,90x13Z=64
PASBF050200	Saw blade fine VHM-A 50x2,00x13Z=64
PASBF050250	Saw blade fine VHM-A 50x2,50x13Z=64
PASBF050300	Saw blade fine VHM-A 50x3,00x13Z=48
PASBF050350	Saw blade fine VHM-A 50x3,50x13Z=48
PASBF050400	Saw blade fine VHM-A 50x4,00x13Z=48
PASBF050500	Saw blade fine VHM-A 50x5,00x13Z=48
PASBF050600	Saw blade fine VHM-A 50x6,00x13Z=40
PASBF063030	Saw blade fine VHM-A 63x0,30x16Z128
PASBF063035	Saw blade fine VHM-A 63x0,35x16Z128
PASBF063040	Saw blade fine VHM-A 63x0,40x16Z128

Art. No.	Saw blades fine
PASBF063050	Saw blade fine VHM-A 63x0,50x16Z128
PASBF063060	Saw blade fine VHM-A 63x0,60x16Z100
PASBF063070	Saw blade fine VHM-A 63x0,70x16Z100
PASBF063080	Saw blade fine VHM-A 63x0,80x16Z100
PASBF063090	Saw blade fine VHM-A 63x0,90x16Z100
PASBF063100	Saw blade fine VHM-A 63x1,00x16Z100
PASBF063110	Saw blade fine VHM-A 63x1,10x16Z=80
PASBF063120	Saw blade fine VHM-A 63x1,20x16Z=80
PASBF063130	Saw blade fine VHM-A 63x1,30x16Z=80
PASBF063140	Saw blade fine VHM-A 63x1,40x16Z=80
PASBF063150	Saw blade fine VHM-A 63x1,50x16Z=80
PASBF063160	Saw blade fine VHM-A 63x1,60x16Z=80
PASBF063170	Saw blade fine VHM-A 63x1,70x16Z=80
PASBF063180	Saw blade fine VHM-A 63x1,80x16Z=80
PASBF063190	Saw blade fine VHM-A 63x1,90x16Z=80
PASBF063200	Saw blade fine VHM-A 63x2,00x16Z=80
PASBF063250	Saw blade fine VHM-A 63x2,50x16Z=64
PASBF063300	Saw blade fine VHM-A 63x3,00x16Z=64
PASBF063350	Saw blade fine VHM-A 63x3,50x16Z=64
PASBF063400	Saw blade fine VHM-A 63x4,00x16Z=64
PASBF063500	Saw blade fine VHM-A 63x5,00x16Z=48
PASBF063600	Saw blade fine VHM-A 63x6,00x16Z=48
PASBF080030	Saw blade fine VHM-A 80x0,30x22Z160
PASBF080035	Saw blade fine VHM-A 80x0,35x22Z160
PASBF080040	Saw blade fine VHM-A 80x0,40x22Z160
PASBF080050	Saw blade fine VHM-A 80x0,50x22Z128
PASBF080060	Saw blade fine VHM-A 80x0,60x22Z128
PASBF080070	Saw blade fine VHM-A 80x0,70x22Z128
PASBF080080	Saw blade fine VHM-A 80x0,80x22Z128
PASBF080090	Saw blade fine VHM-A 80x0,90x22Z100
PASBF080100	Saw blade fine VHM-A 80x1,00x22Z100
PASBF080110	Saw blade fine VHM-A 80x1,10x22Z100
PASBF080120	Saw blade fine VHM-A 80x1,20x22Z100
PASBF080130	Saw blade fine VHM-A 80x1,30x22Z100
PASBF080140	Saw blade fine VHM-A 80x1,40x22Z100
PASBF080150	Saw blade fine VHM-A 80x1,50x22Z100
PASBF080160	Saw blade fine VHM-A 80x1,60x22Z100
PASBF080170	Saw blade fine VHM-A 80x1,70x22Z=80
PASBF080180	Saw blade fine VHM-A 80x1,80x22Z=80
PASBF080190	Saw blade fine VHM-A 80x1,90x22Z=80
PASBF080200	Saw blade fine VHM-A 80x2,00x22Z=80
PASBF080250	Saw blade fine VHM-A 80x2,50x22Z=80
PASBF080300	Saw blade fine VHM-A 80x3,00x22Z=80
PASBF080350	Saw blade fine VHM-A 80x3,50x22Z=64
PASBF080400	Saw blade fine VHM-A 80x4,00x22Z=64
PASBF080500	Saw blade fine VHM-A 80x5,00x22Z=64
PASBF080600	Saw blade fine VHM-A 80x6,00x22Z=64
PASBF100050	Saw blade fine VHM-A100x0,50x22Z160
PASBF100060	Saw blade fine VHM-A100x0,60x22Z160
PASBF100070	Saw blade fine VHM-A100x0,70x22Z128
PASBF100080	Saw blade fine VHM-A100x0,80x22Z128
PASBF100090	Saw blade fine VHM-A100x0,90x22Z128
PASBF100100	Saw blade fine VHM-A100x1,00x22Z128
PASBF100110	Saw blade fine VHM-A100x1,10x22Z128
PASBF100120	Saw blade fine VHM-A100x1,20x22Z128
PASBF100130	Saw blade fine VHM-A100x1,30x22Z100
PASBF100140	Saw blade fine VHM-A100x1,40x22Z100
PASBF100150	Saw blade fine VHM-A100x1,50x22Z100
PASBF100160	Saw blade fine VHM-A100x1,60x22Z100
PASBF100170	Saw blade fine VHM-A100x1,70x22Z100
PASBF100180	Saw blade fine VHM-A100x1,80x22Z100
PASBF100190	Saw blade fine VHM-A100x1,90x22Z100
PASBF100200	Saw blade fine VHM-A100x2,00x22Z100
PASBF100250	Saw blade fine VHM-A100x2,50x22Z100
PASBF100300	Saw blade fine VHM-A100x3,00x22Z=80
PASBF100350	Saw blade fine VHM-A100x3,50x22Z=80
PASBF100400	Saw blade fine VHM-A100x4,00x22Z=80
PASBF100500	Saw blade fine VHM-A100x5,00x22Z=80
PASBF100600	Saw blade fine VHM-A100x6,00x22Z=64



Art. No.	Saw blades rough
PASBG020020	Saw blade rough VHM-B 20x0,20x5-Z=20
PASBG020025	Saw blade rough VHM-B 20x0,25x5-Z=20
PASBG020030	Saw blade rough VHM-B 20x0,30x5-Z=20
PASBG020040	Saw blade rough VHM-B 20x0,40x5-Z=20
PASBG020050	Saw blade rough VHM-B 20x0,50x5-Z=20
PASBG020060	Saw blade rough VHM-B 20x0,60x5-Z=20
PASBG020070	Saw blade rough VHM-B 20x0,70x5-Z=20
PASBG020080	Saw blade rough VHM-B 20x0,80x5-Z=20
PASBG020090	Saw blade rough VHM-B 20x0,90x5-Z=20
PASBG020100	Saw blade rough VHM-B 20x1,00x5-Z=20
PASBG020120	Saw blade rough VHM-B 20x1,20x5-Z=20
PASBG020150	Saw blade rough VHM-B 20x1,50x5-Z=20
PASBG020160	Saw blade rough VHM-B 20x1,60x5-Z=20
PASBG020180	Saw blade rough VHM-B 20x1,80x5-Z=20
PASBG020200	Saw blade rough VHM-B 20x2,00x5-Z=20
PASBG020250	Saw blade rough VHM-B 20x2,50x5-Z=20
PASBG020300	Saw blade rough VHM-B 20x3,00x5-Z=20
PASBG020400	Saw blade rough VHM-B 20x4,00x5-Z=20
PASBG020500	Saw blade rough VHM-B 20x5,00x5-Z=20
PASBG020600	Saw blade rough VHM-B 20x6,00x5-Z=20
PASBG025020	Saw blade rough VHM-B 25x0,20x8-Z=20
PASBG025025	Saw blade rough VHM-B 25x0,25x8-Z=20
PASBG025030	Saw blade rough VHM-B 25x0,30x8-Z=20
PASBG025040	Saw blade rough VHM-B 25x0,40x8-Z=20
PASBG025050	Saw blade rough VHM-B 25x0,50x8-Z=20
PASBG025060	Saw blade rough VHM-B 25x0,60x8-Z=20
PASBG025070	Saw blade rough VHM-B 25x0,70x8-Z=20
PASBG025080	Saw blade rough VHM-B 25x0,80x8-Z=20
PASBG025090	Saw blade rough VHM-B 25x0,90x8-Z=20
PASBG025100	Saw blade rough VHM-B 25x1,00x8-Z=20
PASBG025120	Saw blade rough VHM-B 25x1,20x8-Z=20
PASBG025150	Saw blade rough VHM-B 25x1,50x8-Z=20
PASBG025160	Saw blade rough VHM-B 25x1,60x8-Z=20
PASBG025180	Saw blade rough VHM-B 25x1,80x8-Z=20
PASBG025200	Saw blade rough VHM-B 25x2,00x8-Z=20
PASBG025250	Saw blade rough VHM-B 25x2,50x8-Z=20
PASBG025300	Saw blade rough VHM-B 25x3,00x8-Z=20
PASBG025400	Saw blade rough VHM-B 25x4,00x8-Z=20
PASBG025500	Saw blade rough VHM-B 25x5,00x8-Z=20
PASBG025600	Saw blade rough VHM-B 25x6,00x8-Z=20
PASBG030020	Saw blade rough VHM-B 30x0,20x8-Z=30
PASBG030025	Saw blade rough VHM-B 30x0,25x8-Z=30
PASBG030030	Saw blade rough VHM-B 30x0,30x8-Z=30
PASBG030040	Saw blade rough VHM-B 30x0,40x8-Z=30
PASBG030050	Saw blade rough VHM-B 30x0,50x8-Z=30
PASBG030060	Saw blade rough VHM-B 30x0,60x8-Z=30
PASBG030070	Saw blade rough VHM-B 30x0,70x8-Z=30
PASBG030080	Saw blade rough VHM-B 30x0,80x8-Z=24
PASBG030090	Saw blade rough VHM-B 30x0,90x8-Z=24
PASBG030100	Saw blade rough VHM-B 30x1,00x8-Z=24
PASBG030120	Saw blade rough VHM-B 30x1,20x8-Z=24
PASBG030150	Saw blade rough VHM-B 30x1,50x8-Z=24
PASBG030160	Saw blade rough VHM-B 30x1,60x8-Z=24
PASBG030180	Saw blade rough VHM-B 30x1,80x8-Z=24
PASBG030200	Saw blade rough VHM-B 30x2,00x8-Z=24
PASBG030250	Saw blade rough VHM-B 30x2,50x8-Z=24
PASBG030300	Saw blade rough VHM-B 30x3,00x8-Z=24
PASBG030400	Saw blade rough VHM-B 30x4,00x8-Z=24
PASBG030500	Saw blade rough VHM-B 30x5,00x8-Z=24
PASBG030600	Saw blade rough VHM-B 30x6,00x8-Z=24
PASBG040020	Saw blade rough VHM-B 40x0,20x10-Z40
PASBG040025	Saw blade rough VHM-B 40x0,25x10-Z40
PASBG040030	Saw blade rough VHM-B 40x0,30x10-Z40
PASBG040040	Saw blade rough VHM-B 40x0,40x10-Z40
PASBG040050	Saw blade rough VHM-B 40x0,50x10-Z40
PASBG040060	Saw blade rough VHM-B 40x0,60x10-Z40
PASBG040070	Saw blade rough VHM-B 40x0,70x10-Z40
PASBG040080	Saw blade rough VHM-B 40x0,80x10-Z32
PASBG040090	Saw blade rough VHM-B 40x0,90x10-Z32

Saw blades

Art. No.	Saw blades rough
PASBG040100	Saw blade rough VHM-B 40x1,00x10-Z32
PASBG040120	Saw blade rough VHM-B 40x1,20x10-Z32
PASBG040150	Saw blade rough VHM-B 40x1,50x10-Z32
PASBG040160	Saw blade rough VHM-B 40x1,60x10-Z32
PASBG040180	Saw blade rough VHM-B 40x1,80x10-Z32
PASBG040200	Saw blade rough VHM-B 40x2,00x10-Z32
PASBG040250	Saw blade rough VHM-B 40x2,50x10-Z32
PASBG040300	Saw blade rough VHM-B 40x3,00x10-Z32
PASBG040400	Saw blade rough VHM-B 40x4,00x10-Z32
PASBG040500	Saw blade rough VHM-B 40x5,00x10-Z32
PASBG040600	Saw blade rough VHM-B 40x6,00x10-Z32
PASBG050040	Saw blade rough VHM-B 50x0,40x13-Z48
PASBG050050	Saw blade rough VHM-B 50x0,50x13-Z48
PASBG050060	Saw blade rough VHM-B 50x0,60x13-Z48
PASBG050070	Saw blade rough VHM-B 50x0,70x13-Z40
PASBG050080	Saw blade rough VHM-B 50x0,80x13-Z40
PASBG050090	Saw blade rough VHM-B 50x0,90x13-Z40
PASBG050100	Saw blade rough VHM-B 50x1,00x13-Z40
PASBG050120	Saw blade rough VHM-B 50x1,20x13-Z40
PASBG050150	Saw blade rough VHM-B 50x1,50x13-Z32
PASBG050160	Saw blade rough VHM-B 50x1,60x13-Z32
PASBG050180	Saw blade rough VHM-B 50x1,80x13-Z32
PASBG050200	Saw blade rough VHM-B 50x2,00x13-Z32
PASBG050250	Saw blade rough VHM-B 50x2,50x13-Z32
PASBG050300	Saw blade rough VHM-B 50x3,00x13-Z24
PASBG050400	Saw blade rough VHM-B 50x4,00x13-Z24
PASBG050500	Saw blade rough VHM-B 50x5,00x13-Z24
PASBG050600	Saw blade rough VHM-B 50x6,00x13-Z20
PASBG063040	Saw blade rough VHM-B 63x0,40x16-Z64
PASBG063050	Saw blade rough VHM-B 63x0,50x16-Z64
PASBG063060	Saw blade rough VHM-B 63x0,60x16-Z48
PASBG063070	Saw blade rough VHM-B 63x0,70x16-Z48
PASBG063080	Saw blade rough VHM-B 63x0,80x16-Z48
PASBG063090	Saw blade rough VHM-B 63x0,90x16-Z48
PASBG063100	Saw blade rough VHM-B 63x1,00x16-Z48
PASBG063120	Saw blade rough VHM-B 63x1,20x16-Z40
PASBG063150	Saw blade rough VHM-B 63x1,50x16-Z40
PASBG063160	Saw blade rough VHM-B 63x1,60x16-Z40
PASBG063180	Saw blade rough VHM-B 63x1,80x16-Z40
PASBG063200	Saw blade rough VHM-B 63x2,00x16-Z40
PASBG063250	Saw blade rough VHM-B 63x2,50x16-Z32
PASBG063300	Saw blade rough VHM-B 63x3,00x16-Z32
PASBG063400	Saw blade rough VHM-B 63x4,00x16-Z32
PASBG063500	Saw blade rough VHM-B 63x5,00x16-Z24
PASBG063600	Saw blade rough VHM-B 63x6,00x16-Z24
PASBG080060	Saw blade rough VHM-B 80x0,60x22-Z64
PASBG080070	Saw blade rough VHM-B 80x0,70x22-Z64
PASBG080080	Saw blade rough VHM-B 80x0,80x22-Z64
PASBG080090	Saw blade rough VHM-B 80x0,90x22-Z48
PASBG080100	Saw blade rough VHM-B 80x1,00x22-Z48
PASBG080120	Saw blade rough VHM-B 80x1,20x22-Z48
PASBG080150	Saw blade rough VHM-B 80x1,50x22-Z48
PASBG080160	Saw blade rough VHM-B 80x1,60x22-Z48
PASBG080180	Saw blade rough VHM-B 80x1,80x22-Z40
PASBG080200	Saw blade rough VHM-B 80x2,00x22-Z40
PASBG080250	Saw blade rough VHM-B 80x2,50x22-Z40
PASBG080300	Saw blade rough VHM-B 80x3,00x22-Z40
PASBG080400	Saw blade rough VHM-B 80x4,00x22-Z32
PASBG080500	Saw blade rough VHM-B 80x5,00x22-Z32
PASBG080600	Saw blade rough VHM-B 80x6,00x22-Z32
PASBG100060	Saw blade rough VHM-B100x0,60x22Z=80
PASBG100070	Saw blade rough VHM-B100x0,70x22Z=80
PASBG100080	Saw blade rough VHM-B100x0,80x22Z=64
PASBG100090	Saw blade rough VHM-B100x0,90x22Z=64
PASBG100100	Saw blade rough VHM-B100x1,00x22Z=64
PASBG100120	Saw blade rough VHM-B100x1,20x22Z=64
PASBG100150	Saw blade rough VHM-B100x1,50x22Z=48
PASBG100160	Saw blade rough VHM-B100x1,60x22Z=48
PASBG100180	Saw blade rough VHM-B100x1,80x22Z=48

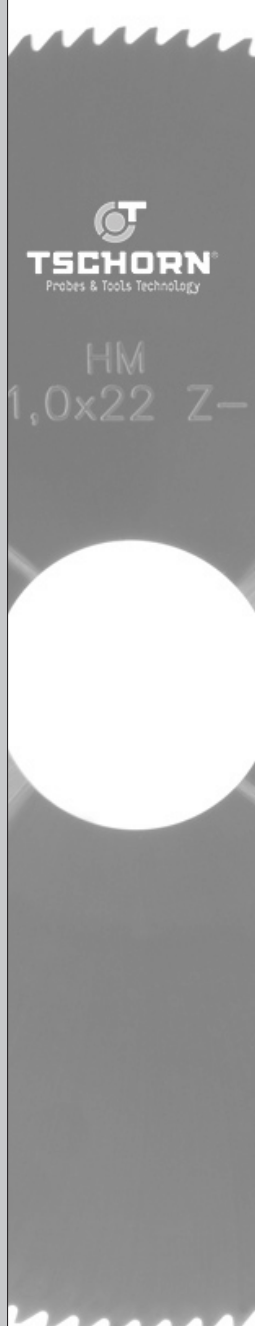

Art. No.	Saw blades rough
PASBG100200	Saw blade rough VHM-B100x2,00x22Z=48
PASBG100250	Saw blade rough VHM-B100x2,50x22Z=48
PASBG100300	Saw blade rough VHM-B100x3,00x22Z=40
PASBG100400	Saw blade rough VHM-B100x4,00x22Z=40
PASBG100500	Saw blade rough VHM-B100x5,00x22Z=40
PASBG100600	Saw blade rough VHM-B100x6,00x22Z=32